

# OPERATING AND MAINTENANCE INSTRUCTIONS

## QUARTER-FLEX HIGH PERFORMANCE BUTTERFLY VALVE

2 1/2 - 24", 1150/2150 and  
1151/2151 ANSI Class 150

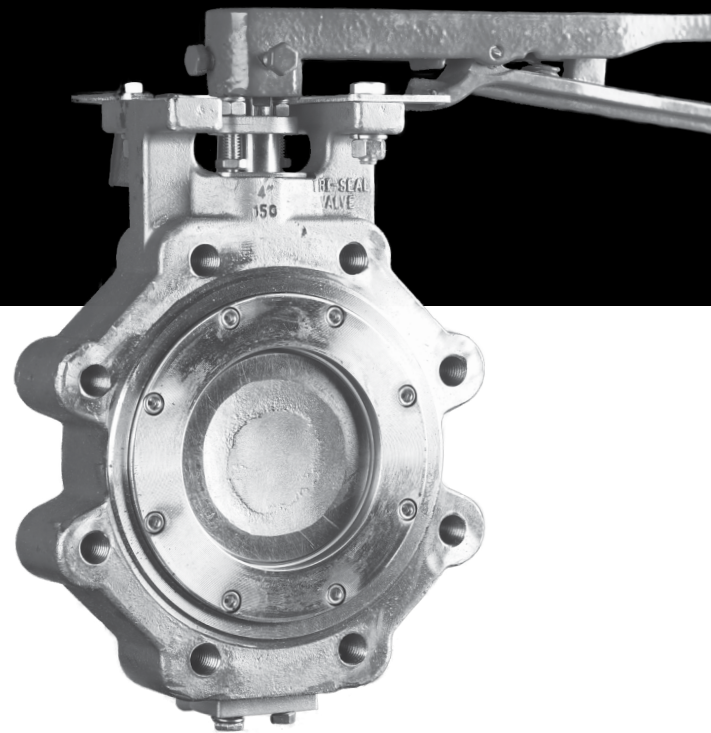

### Table of Contents:

Design Overview .....	2
Installation Instructions .....	2
Valve Operation .....	2
Maintenance.....	3
Troubleshooting .....	3
Dimensions .....	4
Materials of Construction.....	5
Technical Data and Flow Characteristics .....	7



Tri-Seal Quarter-Flex Butterfly Valves contain improvements and refinements not found in any other high performance butterfly valves. These features serve to insure a long and trouble-free life as well as providing simple and less expensive maintenance when required.

## A. DESIGN FEATURES

**1. Seat Design** – The Quarter-Flex valve employs a pressure assisted seat design which seals proportionally tighter as pressure increases. In addition, the spring design is self-compensating for any misalignment which may occur. When the valve is closed, the disc is forced into the seat for initial sealing. The line pressure exerts an upward force on the seat which forces the seat against the valve disc, “accordion” style. Increased line pressure causes tighter sealing, which assures continuous bubble-tight closure.

**2. Body Design** – The Quarter-Flex valve employs a rugged one-piece body design with an integrally cast travel stop and installation guides for flange bolts. These guide holes have sufficient clearance to allow flexibility for misalignment of mating flanges.

**3. Shaft Design** – The Quarter-Flex shaft is a double offset style with one-piece construction design through 16” size, two-piece construction 18” and larger.

**4. Gland Design** – The Quarter-Flex packing gland is a TFE Vee-Ring design. This design is pressure sensitive; that is, the packing offers excellent sealing characteristics along with minimum torque build-up. Adjustment, when necessary, can be accomplished by tightening the gland retainer with simple hand tools.

**5. Disc Design** – The Quarter-Flex disc is of rugged construction with a sealing edge which is a segment of a ball. Once the disc is forced into the seat, a bubble-tight seal is effected. Any change of position of the disc once it is forced into the seat will not affect performance. The result being that (within the width of the edge), an exact stop position is not critical.

## B. INSTALLATION

1. The Quarter-Flex Series valves are bi-directional, and as such can be installed for flow in either direction. However, a preferred flow is indicated.

2. When installing a butterfly valve always be sure that a new flange gasket of the proper material for the intended service media is used.

3. When installing flange bolts, always tighten bolts in a sequential pattern, shown in Fig. 1. Bolts should be tightened to the appropriate torque as specified by SAE for the bolting material used.

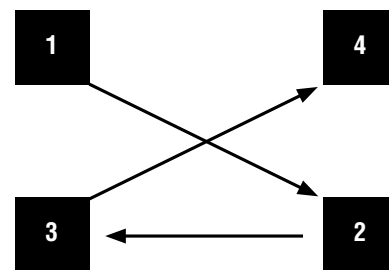

Figure 1: Flange bolt tightening sequence

NOTE: After bolts have been tightened, it is good practice to recheck flange bolt torques one-half to one hour after initial tightening (particularly when stainless steel bolting is used.)  
WARNING: As is the case with most valve types available on the market today, (regardless of manufacturer), valve stem seals may require periodic adjustment, therefore, installations that do not allow access to the valve stem should be avoided.

## C. VALVE OPERATION

1. All Tri-Seal Valve Quarter-Flex Butterfly valves feature ¼ turn operation. Turning the valve handle 90 degrees clockwise will fully close the valve, while 90 degree counter-clockwise rotation will fully open the valve. The valve handle also serves as a disc position indicator. When the valve handle is parallel to the pipe, the valve is open, when perpendicular to the pipe, the valve is closed. To disengage the handle from the locking plate simply squeeze the bottom lever of the handle.

2. All Tri-Seal Valve Quarter-Flex Butterfly valves are designed to provide bubble tight performance when properly selected in accordance with the valve’s pressure/temperature rating, unless otherwise noted in the seat material selection chart.

3. To provide the longest possible service life, a hand operated butterfly valve should be operated in either its fully open or fully closed position. However, a 10 position locking plate is provided if an intermediate operating position is desired.

4. The torques listed under “Break Away” at the end of this instruction sheet are the normal expected breakaway torques. These values represent the maximum force required to begin to open the valve at specified differential pressures. Typically, this breakaway torque is the maximum torque requirement for the valve during a closed-to-open, open-to-close cycle. Bear in mind that these have been confirmed by laboratory testing of each valve size while pressurized with water to its maximum pressure rating (certain highly viscous or abrasive services could cause an increase in torque requirements).

## D. MAINTENANCE

During its normal service life, the only maintenance that may be required should be periodic stem seal adjustment. If leakage at the stem is noted, simply tighten the packing plate until leakage subsides. **DO NOT OVER TIGHTEN AS PREMATURE WEAR COULD RESULT.** It is impractical to predict frequency of stem adjustment, as it is influenced by such factors as frequency of cycling and service media. **IMPORTANT:** As is the case with ANY valve on the market today, it is important that stem leaks do not go unattended. Lack of maintenance of stem leakage could cause a premature need to replace stem seals. **NOTE:** If operating temperature of system is substantially higher or lower than 80° F, initial stem seal adjustment may be required to prevent leakage.

## E. DISASSEMBLY

**WARNING:** Most standard bi-directional High Performance butterfly valves on the market today, regardless of manufacturer, can trap fluid in the valve cavity when closed. If your Tri-Seal Valve Quarter-Flex butterfly valve has been used to conduct a hazardous media, the following steps must be taken prior to removal from line and disassembled.

1. Relieve line pressure.
2. Place valve in its half-open position and flush the line to remove the hazardous material from the valve cavity. The valve can now be removed from the line. **NOTE:** Always advise maintenance personnel when they are maintaining or rebuilding a valve that has been conducting hazardous material. Proper protective clothing and eye protection should always be utilized.
3. To disassemble entire valve:
  - a. Having assured that BOTH line and valve cavity pressures have been relieved, remove the valve from the line.
  - b. Place the valve in a vice or other suitable retention tool that will adequately support the valve while it is being disassembled.

c. To access the seat, remove seat retainer by the appropriate method listed below:

### WAFER STYLE (2 1/2” – 14” ONLY)

With the valve slightly open, rotate the seat retainer such that the notches are no longer in the 12 and 6 o'clock positions. Lift seat retainer to remove from the valve. Care should be taken so as not to lose the seat retainer lock pins and springs or retaining spring, as they could dislodge from the holes in the retainer.

### LUG STYLE (16” – 24” WAFER)

Remove all retainer socket head cap screws. Lift seat retainer to remove from valve.

- d. Remove valve handle by loosening hex head cap crew and sliding handle off of shaft.
- e. Remove hex head cap crews, lock washers and positioning plate from top mounting flange.
- f. Remove self locking gland retainer hex nuts and gland retainer.
- g. Remove jam nuts, shaft retaining plate and outer gland ring.
- h. Remove shaft retaining ring (2 1/2” through 14” only) stem packing and inner gland ring.
- i. Remove hex head cap screws, lock washers, and cap on the bottom of the valve.
- j. Remove key (2 1/2”-8”) or pins (10”-24”) from disc and shaft assembly. For key removal: grind off spot welds and punch out key. For pin removal: All dowel pins have been drilled and tapped to facilitate their extraction. The thread sizes are as follows: 10”-20” = ¼ - 20, 24” = 3/8-16.
- k. Slide shaft from valve body, lift out disc and thrust washers located at the top and bottom of shaft bore.
- l. Care should be taken when replacing the bearings, as they can be damaged while pressing them out.

## F. REASSEMBLY

Having assured that all critical surfaces have been inspected, cleaned and/or replaced, reassembly can begin.

- a. If replacing shaft bearings, carefully press bearings into the shaft bore of the valve body until bearings are flush with shoulder inside bore.
  - b. While holding the thrust washers against the milled spot faces on the O.D. of the disc, insert the disc into the valve and align the disc shaft bore with the body bore.
- NOTE:** Be sure that the disc is orientated such that the “T” on the keyed disc (8” and smaller) or the dowel pin holes (10” and larger) are located toward the side opposite of the seat retainer and near the packing side.

c. Insert the shaft through the shaft bore and disc, ensuring proper alignment of the key way or pin holes to the same of the disc.

d. Press the key or dowel pins in place and stake to secure.

NOTE: Key should be tack-welded to insure proper operation.

e. Insert the seal into the seat retainer ensuring the flat back of the seat is flush with the top edge of the retainer.

CAUTION: Care must be exercised to assure the seat is not installed upside down. Install the seat retainer lock pins and springs into the (2) holes in the outside diameter of the seat retainer if the valves are so equipped. If the valves have a groove around the outside diameter of the seat retainer then the (2) retaining springs must be used in place of the lock pins. With seat retainer notches located at the 6 and 12 o'clock positions insert the retaining springs as follows; insert the straight leg of the retaining spring into the hole located at the bottom of the groove on the OD of the retainer to the left of the notch which is located at 12 o'clock making sure that other end of the spring is extending to the right. Then insert the remaining spring into the hole located to the right of the notch located at 6 o'clock with the opposite end extending to the left. NOTE: See enclosed drawing for location of retaining springs.

f. With the valve in the closed position and laying flat on a safe working surface, place the seat retainer, seat and seat retainer retaining springs or lock pins assembly into the valve body such that the seat sits on the disc sealing edge and is not pinched or damaged by the disc/seat retainer.

g. To secure the seat retainer to the valve body use the following procedure:

WAFER (2 1/2"-14") ONLY – With one side of the seat retainer pressed into the valve body, depress seat retainer lock pin or the seat retainer retaining spring and push the seat retainer down so that it is flush to .010 above the body. Rotate seat retainer until the notches are in the 6 and 12 o'clock positions locking the lock pins or retaining springs in place. In addition, it must be noted that repair kits will include parts for both methods of retaining the seat retainer and that the extra parts should be discarded.  
LUG (and Wafer 16"-24") – Install and tighten socket head cap crews insuring the retainer is bottomed in body.

h. Install inner gland ring into shaft bore. Install Vee-Ring packing one piece at a time, male adapter piece first (flat side against gland ring). Install the remaining pieces so that an upside down "V" is formed (this allows the

line pressure to force the "V" to expand, thus sealing the shaft bore). The female adapter piece should be installed last. NOTE: For high vacuum service, the order and direction of the packing should be reversed.

i. Install shaft-retaining ring into groove on shaft. Slide outer gland ring onto the shaft and place nameplate and shaft retaining plate onto gland retaining studs. Secure with jam nuts

j. Install gland retainer plate and secure finger tight with self-locking retainer nuts. Tighten as required when installed into service.

k. Install O-ring and end cap onto the bottom of the valve and secure with lock washers and hex head cap crews.

l. Place positioning plate onto mounting flange and secure finger tight with lock washers and hex head cap screws. NOTE: The overhang of the plate should be behind and to the right of the seat retainer while looking at the retainer side of the valve.

m. With the valve in an approximate closed position slide the handle onto the shaft so that the bottom tang of the handle engages the positioning plate. Secure handle to shaft by tightening hex head cap screw on handle. Rotate the valve to it's fully closed position if the handle is not locked into the last notch of the positing plate.

**F. Common problems** encountered with high performance butterfly valves (with associated corrective action options).

a. Shaft Leakage:

1. Tighten gland retainer nuts (careful not to over tighten – just enough so leakage stops).
2. Replace gland packing

b. Leakage between Flange and Valve:

1. Tighten flange bolts
2. Replace flange gasket

c. Leakage through Valve Seat:

1. Clean seat and retainer groove
2. Replace seat
3. Reposition seat on disc if evidence of minor damage is visible
4. Replace disc and shaft assembly

d. Excessive Torque:

1. Check alignment of valve actuator and adjust if side loading is evident
2. Replace bearings if slight galling has occurred on shaft
3. Replace bearing and shaft if galling is excessive.

## MATERIALS OF CONSTRUCTION - ANSI CLASS 150

**Keyed Stem**  
10"-24" Cl. 150  
8"-12" Cl. 300

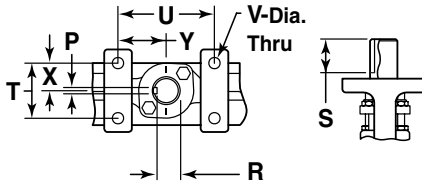

**Flatted Stem**  
2 1/2"-8" Cl. 150  
3"-6" Cl. 300

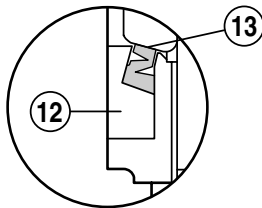
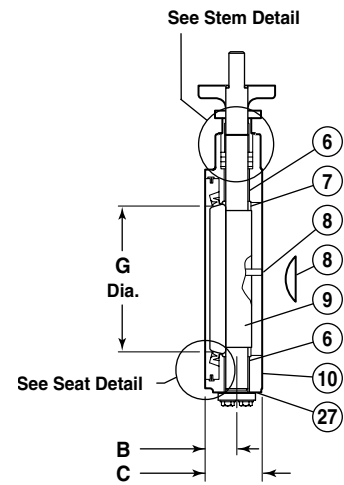
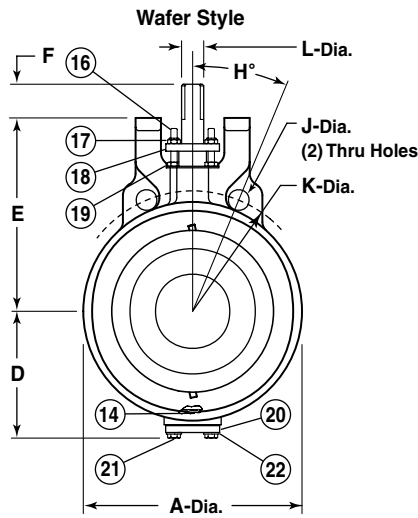
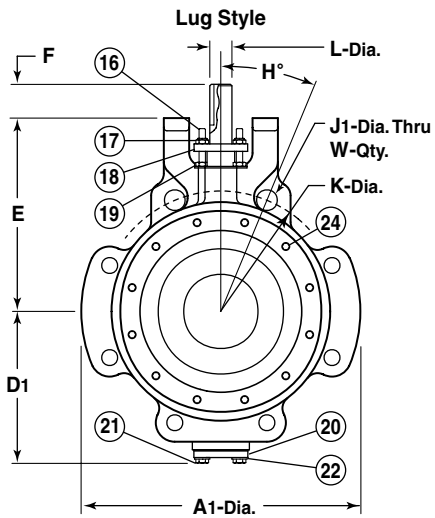
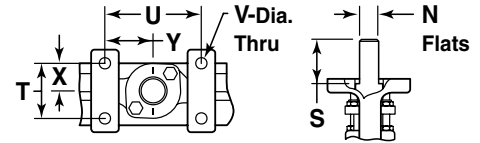

**Lug Style  
Seat Detail**

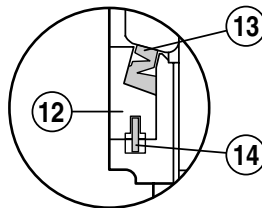

**Wafer Style  
Seat Detail**

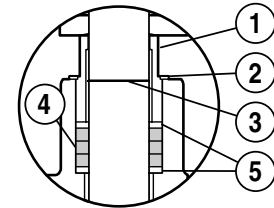

**Stem Detail**

**MATERIALS OF CONSTRUCTION**

Materials		Carbon Steel	Stainless Steel
Part	Name	1150 / 1151 / 1300 / 1301	2150 / 2151 / 2300 / 2301
1	Outer Gland Ring	300 Series Stainless Steel	
2	Shaft Ret. Plate	300 Series Stainless Steel	
3	Shaft Ret. Ring	300 Series Stainless Steel	
4	Packing	PTFE/Graphite	
5	Inner Gland Ring	316 Stainless Steel	
6	Bearing	High Temp Composite backed RPTFE or 316 Stainless Steel RPTFE backed	
7	Thrust Washer	316 Stainless Steel	
8	Key/Pin	Key 316 or 17-4 Stainless Steel / PIN 316 Stainless Steel	
9	Shaft/Disc Assembly	2 1/2" -10" (316 Stainless Steel Shaft / CF8M Disc) 12" - 36" (17.4 Shaft / CF8M Disc)	
10	Body	ASTM A216 Grade WCB	ASTM A351 Grade CF8M
12	Seat Retainer	ASTM A515 or 516 GR 70	ASTM A240 GR 316 SS
13	Seat	PTFE/RPTFE/UHMW	
14	Retaining Spring	Inconel X750	
16	Stud	18-8 Stainless Steel	
17	Self Locking Nut	18-8 Nyloc Stainless Steel	
18	Gland Retainer	300 Series Stainless Steel	
19	Jam Nut	18-8 Stainless Steel	
20	End Cap	316 Stainless Steel	
21	Hex Head Cap Screw	18-8 Stainless Steel	
22	Split Lockwasher	18-8 Stainless Steel	
23	Name Plate	300 Series Stainless Steel	
24	Sockethead Cap Screw	18-8 Stainless Steel	
27	End Cap Seal	Teflon®/ Viton®/Grafoil	

**Note:** Listed are standard materials of construction. Optional Materials may be substituted. Please consult the How to Order guide for various trims. Teflon® & Viton® are registered trademarks of DuPont Dow Elastomers.

## TECHNICAL DATA

### Valve Operating and Rating Information

#### Pressure Rating at 100°F

Class 150: 285 PSIG (A216 Gr. WCB)  
275 PSIG (A351 Gr. CF8M)

Class 300: 740 PSIG (A216 Gr. WCB)  
720 PSIG (A351 Gr. CF8M)

#### Maximum Temperature for Seats and Seals at 0 PSIG

PTFE 425°F  
Reinforce PTFE 450°F  
UHMWPE 180°F

#### Minimum Operating Temperature

-35°F

#### Steam Rating (Saturated)

PTFE 70 WSP  
RPTFE 150 WSP  
(On/off service only. For throttling application, consult factory.)

## Technical Charts and Data

### Pressure Temperature Chart

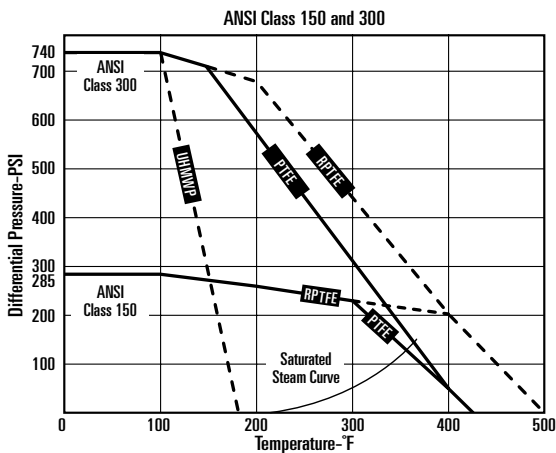

**NOTE:** Maximum continuous operating temperature. Consult factory for application above those shown.

### Flow Coefficients (Cv)

Valve Size (in.)	CV Flow Coefficient	
	Class 150	Class 300
2 ½	90	
3	205	205
4	403	403
5	640	
6	1075	1075
8	2243	1950
10	3885	3100
12	5925	4400
14	7307	
16	10,050	
18	13,075	
20	18,050	
24	26,863	
30	Consult Factory	
36	Consult Factory	

### Flow Characteristics Curve

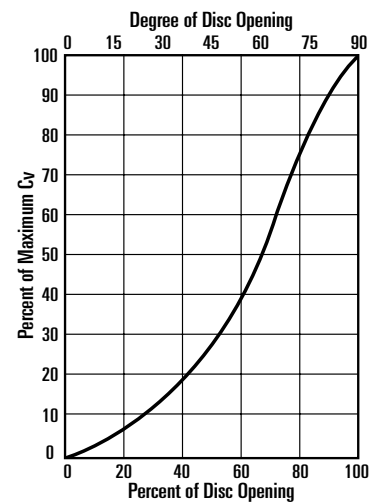

**NOTE:** Flow coefficients (Cv) based on ambient water temperature

# TECHNICAL DATA

## Torque - ANSI Class 150

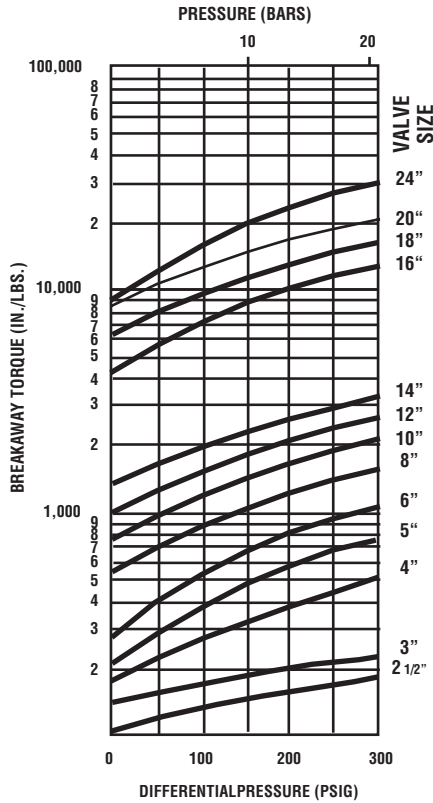

**NOTE:** Torques based on clean service only. Certain highly viscous or abrasive services could increase these values.

## Torque - ANSI Class 300

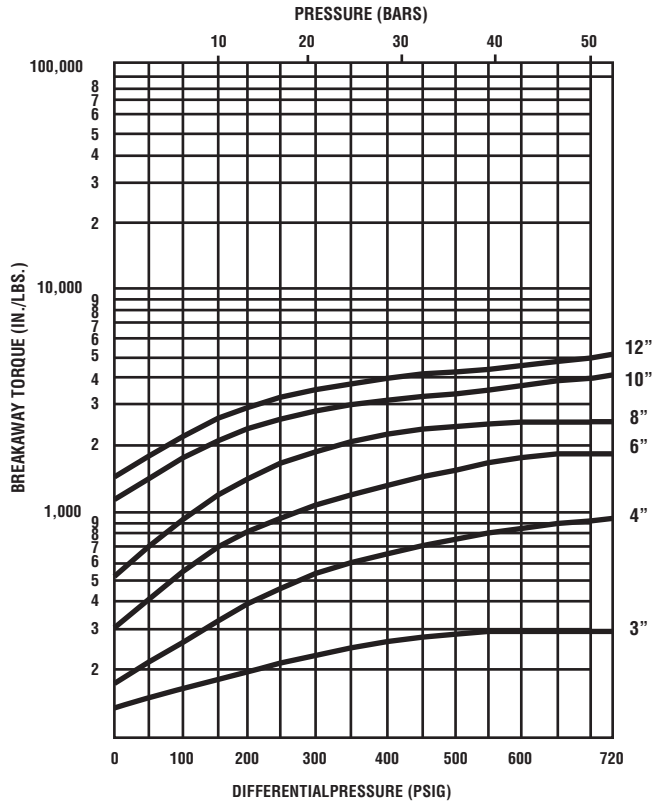

**NOTE:** Torques based on clean service only. Certain highly viscous or abrasive services could increase these values.

## Operating Torque

Operating Torque (in-lbs.)									
PSIG	100		200		285		400	600	740
	150#	300#	150#	300#	150#	300#	300#	300#	300#
2 1/2	140		170		190				
3	160	180	200	210	230	240	280	300	300
4	280	290	400	410	530	560	650	800	1000
5	380		550		750				
6	540	600	820	900	1100	1150	1500	1800	1900
8	870	1000	1300	1600	1800	1950	2200	2600	2600
10	1350	1800	1700	2500	2200	2900	3200	3900	4200
12	1600	2300	2100	2900	2600	3700	4000	4900	5300
14	1900		2500		3100				
16	7300		11000		13000				
18	9500		13000		16000				
20	13000		17000		21000				
24	16000		24000		31000				
30	29000		39000		49000				
36	48000		69000		82000				

**NOTE:** All torques based on clean service without safety factor



**MPI – MCWANE PLANT & INDUSTRIAL**

1201 Vanderbilt Road Birmingham, AL 35234 866.924.8674 [www.mcwanepi.com](http://www.mcwanepi.com) [sales@mcwanepi.com](mailto:sales@mcwanepi.com)

Kennedy Valve | Tyler Union | McWane Ductile | Waterman | Tri-Seal Valve