

OVERFLOW RISER VALVES

The Waterman line of OVERFLOW RISER VALVES began with our original design, known as a Yakima Valve, featuring a simple single ring frame for installation in concrete pipe. In recent years frame adaptations have been made for use with steel, and plastic (PIP) low-head irrigation pipe. Cover styles have been added and now include our popular "Red Top" high-strength concave and ribbed design, a smooth convex (domed) "Sunshine" design, and our "Pasture" design which features a flush, key operated, self-cleaning stem, for use in areas where livestock are present.

Threads available include our popular high strength National Standard (vee) thread form, many sizes having fast action, double or triple lead threads and a rugged modified acme thread form (acme) for use where shipping or handling damage may be expected. Note: National Standard Threads (vee) will be provided on "Red Top" Valves unless acme is specified, and acme threads will be provided on 6 inch and larger "Sunshine" and "Pasture" Valves unless national standard (vee) threads are specified.

Special threads to interchange with "Martin" and "Snow" Valves can often be provided. Contact the factory with your requirements.

FEATURES

- High Strength, close-grained grey iron frame and cover
- Cast bronze screw with fully machined threads and seal ring.
- Continuous ring, synthetic rubber cover packing and a long-life friction resistant synthetic washer seal.
- Cast-in-place bronze bushing and solid bronze assembly nut.



Red Top Overflow Valve with Yakima Frame (solid arch)



Sunshine Overflow Valve with Patented CIP Frame

SELECT:

- Cover Style
- Thread Form
- Frame Type

Maximum Operating Heads:

6" - 12", 25 feet; 14", 20 feet; 18" - 20", 15 feet; 24", 10 feet; 30" - 36", 10 feet

Maximum Static Heads:

6" - 12", 50 feet; 14", 35 feet; 18" - 20", 30 feet; 24", 20 feet; 30" - 36", 15 feet.

See page 13A for Frame Installations Suggestions

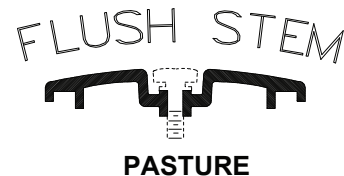

OVERFLOW RISER VALVES

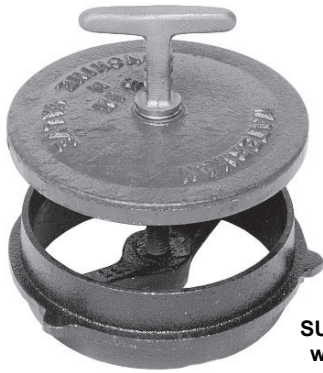

SUNSHINE Overflow Valve
with Yakima Type Frame
(Solid Arch)



PASTURE Overflow Valve
with Type 4 frame.

Note the smooth, slightly domed cover and flush stem. These options serve to protect livestock and reduce problems with vandalism. A hand key or longer key-type spinner handle (ordered separately) is used to open and close the valve.



SELECT:

- COVER STYLE
- THREAD FORM
- FRAME TYPE

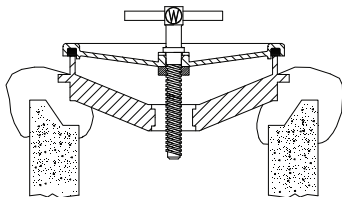

Typical up location,
Red Top cover,
Yakima frame
Overflow Valve for
concrete pipe.

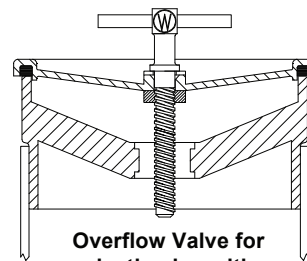

Overflow Valve for
plastic pipe with
type 4 frame and
Red Top cover.

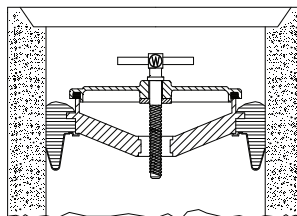

Typical down-setting,
Yakima frame and
Sunshine cover,
shown with Redi-Set
Ring for concrete pipe.

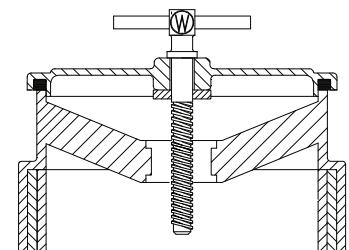

CIP frame for PIP & IPS plastic
pipe. PVC cement bonded.

OVERFLOW RISER VALVES

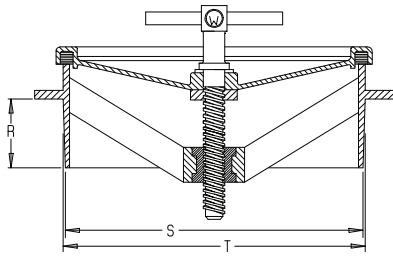

TYPE 4

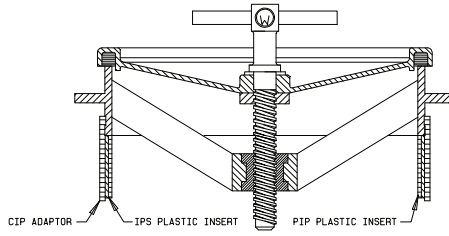

CIP

PARTS LIST		
No.	Name	Qty.
1	Frame	1
2	Cover	1
3	Screw	1
4	Seal	1
5	Nut	1
6	Washer	1

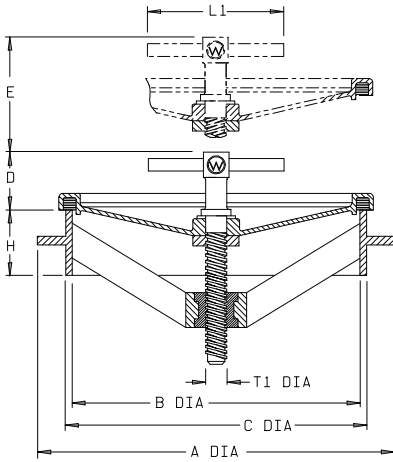

**RED TOP
FOR CONCRETE PIPE**

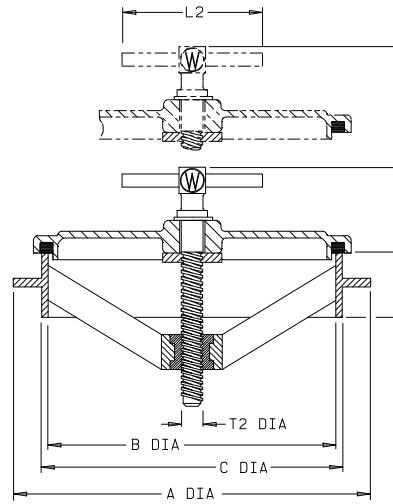

**SUNSHINE
FOR CONCRETE PIPE**

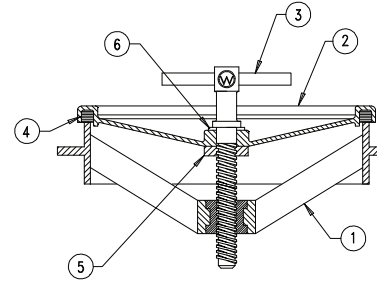

VALVE DIMENSIONS IN INCHES (NOMINAL)

VALVE SIZE	A	B	C	D	E	F	G	H	L1	L2	R	S	T	T1	T2
3	3 ⁹ / ₁₆	2 ⁷ / ₈	3 ³ / ₁₆	2 ¹ / ₂	1 ³ / ₁₆	2 ³ / ₄	3 ³ / ₄	1 ⁵ / ₈	3 ¹ / ₈	3 ¹ / ₈	-	-	-	1 ¹ / ₂	1 ¹ / ₂
3 ¹ / ₂	4 ¹ / ₁₆	3 ¹⁵ / ₁₆	3 ¹ / ₂	2 ⁵ / ₁₆	1 ⁵ / ₁₆	2 ⁷ / ₈	1 ³ / ₁₆	1 ⁷ / ₁₆	3 ¹ / ₈	3 ¹ / ₈	2 ¹ / ₂	3 ¹ / ₂	3 ⁷ / ₈	1 ¹ / ₂	1 ¹ / ₂
4	4 ¹ / ₂	4	4 ¹ / ₄	2 ³ / ₁₆	1 ³ / ₁₆	2 ⁷ / ₈	1 ³ / ₄	1 ⁹ / ₁₆	3 ¹ / ₈	2 ⁷ / ₈	1 ³ / ₈	3 ³ / ₁₆	4 ³ / ₁₆	1 ¹ / ₂	1 ¹ / ₂
5	5 ⁷ / ₈	5	5 ³ / ₈	2 ¹ / ₄	2 ¹ / ₁₆	2 ¹³ / ₁₆	1 ⁵ / ₈	1 ⁷ / ₈	3 ¹ / ₈	2 ⁷ / ₈	3 ¹ / ₄	5 ⁷ / ₁₆	5 ⁷ / ₈	1 ¹ / ₂	1 ¹ / ₂
6	6 ³ / ₈	6	6 ¹ / ₄	2 ³ / ₈	2 ¹³ / ₁₆	2 ¹⁵ / ₁₆	3 ¹ / ₈	1 ¹⁵ / ₁₆	3 ³ / ₄	3 ³ / ₄	3 ¹ / ₄	5 ¹ / ₂	5 ¹³ / ₁₆	5 ⁵ / ₈	5 ⁵ / ₈
6 ¹ / ₂	7 ¹ / ₈	6 ¹ / ₂	6 ³ / ₄	2 ⁵ / ₈	2 ¹ / ₂	2 ⁷ / ₈	2 ⁵ / ₁₆	2	3 ³ / ₄	3 ³ / ₄	-	-	-	5 ⁵ / ₈	5 ⁵ / ₈
8	9 ¹ / ₄	8 ³ / ₈	8 ³ / ₈	2 ³ / ₈	2 ³ / ₁₆	3 ¹ / ₈	2 ⁷ / ₈	2 ¹ / ₄	3 ³ / ₄	3 ⁷ / ₈	3	7 ¹ / ₄	7 ⁷ / ₈	5 ⁵ / ₈	5 ⁵ / ₈
10	10 ³ / ₄	10	10 ⁵ / ₁₆	2 ¹³ / ₁₆	4	3 ¹⁵ / ₁₆	3 ⁷ / ₈	2 ¹ / ₈	4 ¹ / ₂	5	3	9 ³ / ₈	9 ¹³ / ₁₆	3 ³ / ₄	7 ⁷ / ₈
12	12 ¹⁵ / ₁₆	12	12 ¹ / ₂	2 ⁵ / ₁₆	4	3 ⁹ / ₁₆	3 ³ / ₄	1 ¹⁵ / ₁₆	4 ¹ / ₂	7	3 ³ / ₈	11 ⁵ / ₁₆	11 ⁷ / ₈	3 ³ / ₄	1 ¹ / ₈
14	15 ⁵ / ₈	14	14 ¹ / ₂	2 ³ / ₄	4	3 ³ / ₁₆	6 ¹ / ₈	2 ³ / ₁₆	5	8				7 ⁷ / ₈	1 ¹ / ₈
14 x 15	-	-	-	-	-	-	-	-	-	-	4	14 ¹ / ₈	14 ³ / ₄	-	-
16	17 ¹ / ₂	16 ³ / ₈	17	1 ¹ / ₈	4 ³ / ₄	4 ⁵ / ₁₆	4 ⁵ / ₁₆	2 ³ / ₈	8	8	-	-	-	1 ¹ / ₄	1 ¹ / ₄
18	19 ¹ / ₂	18 ³ / ₈	19	1 ¹ / ₁₆	6 ⁷ / ₁₆	4 ⁹ / ₁₆	6 ¹ / ₄	2 ¹ / ₂	8	8	4	17 ⁵ / ₁₆	17 ⁷ / ₈	1 ¹ / ₄	1 ¹ / ₄
20	21 ⁹ / ₁₆	20 ³ / ₈	20 ¹⁵ / ₁₆	1 ¹ / ₈	6 ¹ / ₂	3 ¹ / ₁₆	6 ¹ / ₄	2 ¹ / ₂	8	8	4	19 ⁵ / ₁₆	19 ⁷ / ₈	1 ¹ / ₄	1 ¹ / ₄

PERFORMANCE CHART & PARTS GUIDE

Flow through various size overflow valves, with corresponding pressure loss at rate of discharge

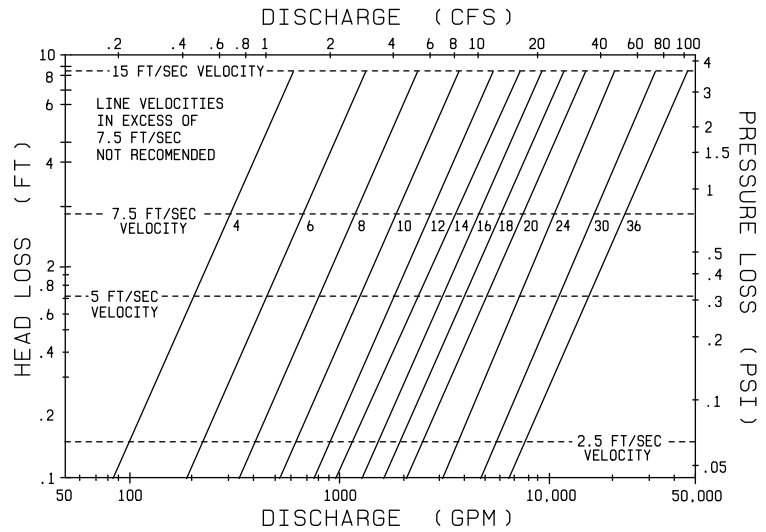

SUNSHINE OVERFLOW VALVE PARTS GUIDE *								
SIZE	COVER	SCREW	YAKIMA FRAME (CONCRETE)		TYPE-4 FRAME (IPS-PIP)		CIP FRAME (IPS-PIP)	
3½"	W656	3½ SS	½"W506B	5S	W102	3½ Y	W1196	-
4"	W1655	4SS	½"W506B	5S	W117	4Y	W1296	W1751-CIP
5"	W1035SS	5SS	½"W598B	5SL	W118	5Y	W1155	-
5" X 6"	W1035SS	5SS	½"W596B	5SL	W118	5Y	W1195	W1792-CIP
6"	W925	6SS	¾"W507B	6S	W120	6Y	W1165	W1787-CIP
6½"	W105SS	6½ SS	¾"W507B	6S	W974	6½ Y	-	-
8"	W146	8SS	¾"W683B	6SL	W121	8Y	W1162	W1788
10"	W141	10SS	¾"W595B	14S	W142	10SS	-	OV-CIP
12"	W143	12SS	1½"W512B	12A	W144	12SS	-	OV-CIP
14"	W148	14SS	1½"W684B	14SS	W149	14SS	-	-
16"	W149	16SS	1¼"W514B	20A	W129	16Y	-	-
18"	W147	18SS	1¼"W685B	20SS	W131	18Y	-	-
20"	W1366	20SS	1¼"W685B	20SS	W133	20Y	-	-

* Numbers beginning with "W" (example: "W130", etc.) are casting numbers which can be located on each cast part.

Numbers which do not begin with "W" are part designations also found on most castings (example: "16A").

RED TOP OVERFLOW VALVE PARTS GUIDE *								
SIZE	COVER	SCREW	YAKIMA FRAME (CONCRETE)		TYPE-4 FRAME (PIP)		CIP FRAME (IPS-PIP)	
3"	W114	3Y	½"W506B	5S	W115	3Y	-	-
3½"	W101	6-0	½"W506B	5S	W102	3½ Y	-	-
4"	W116	4Y	½"W506B	5S	W117	4Y	W1296	W1757-CIP
5"	W103	5Y	½"W598B	5SL	W118	5Y	W1195	-
5" X 6"	W103	5Y	½"W598B	5SL	W118	5Y	-	-
6"	W119	6Y	¾"W507B	6S	W120	6Y	W1165	W1787-CIP
6½"	W105	10-0	¾"W507B	6S	W974	6½ Y	-	-
8"	W107	8Y	¾"W507B	6S	W121	8Y	W1162	W1788-CIP
10"	W122	10Y	¾"W586	10S	W123	10Y	W1163	W1808-CIP
12"	W124	12Y	¾"W586	10S	W125	12Y	W1164	W1809-CIP
14"	W126	14Y	¾"W595B	14S	W127	14Y	W2080 W1194	-
16"	W128	16Y	1¼"W513B	16A	W129	16Y	-	-
18"	W130	18Y	1¼"W514B	20A	W131	18Y	W1659	-
20"	W132	20Y	1¼"W514B	20A	W133	20Y	W1660	-

* Numbers beginning with "W" (example: "W130", etc.) are casting numbers which can be located on each cast part.

Numbers which do not begin with "W" are part designations also found on most castings (example: "16A").

