

# SWING CHECK VALVE

## AWWA C508, SIZES 2" -36"

---

### INSTALLATION & OPERATION MANUAL

TABLE OF CONTENTS	PAGE
Introduction .....	2
Receiving & Storage .....	2
Installation .....	2
Operation .....	3
Maintenance .....	3
Guidelines .....	7
Troubleshooting .....	9
Parts & Service .....	9
Drawings .....	10

# INTRODUCTION

Swing check valves are used for the prevention of backflow in water systems where there is the possibility of a pollutant in the user's system back flowing into the potable water system. They are self-contained, free-swinging disc style which can be purchased with an outside lever and weight or outside lever and spring options conforming to AWWA C508 standards. The valves can also be purchased with outside air or oil cylinders when required by customer requirements or project specifications. Valves sizes 2"-24" can be ordered with double lever arms. Valve sizes 30" and larger come with standard double lever arms.

For check valves to function properly and not be a source of chatter and water hammer, there must be at least ½ psi differential across the valve under normal flow conditions. When in doubt the check valve should be undersized. For service in normal environments (clear water or dry air) at temperatures less than 100°F, resilient seated valves will allow less backflow and minimize water hammer vs. metallic seated valves. For service other than clean water consult the factory.

# RECEIVING & STORAGE

Inspect valves upon receipt to ensure correct material, quantity, and any optional equipment has been received. Also inspect all received equipment for any damage which may have occurred during shipment. Contact the McWane Plant & Industrial sales team to report any issues with materials received.

Unload all valves safely to protect both the materials and workers. Do not allow lifting lugs, slings, or chains to come into contact with the valve disc seating surface areas. Use eyebolts or rods through the flange holes on larger valves.

Whenever possible, check valves should be stored inside. However, when this is not possible or feasible, some outdoor protection must be provided. The valves must be stored in such a manner to protect them from weather, blowing dirt and debris. A tarp covering will minimize exterior coating damage from these elements and reduce fading or chalking due to exposure to the sun. The valves should also be placed in a location where they will not be damaged by collision from vehicles, lift trucks or falling items. Valves should be stored so that water does not stand in the body. In cold climates, if

water is allowed to freeze in the valve, severe damage to the components could result. The valves are shipped in the closed position and should remain in the closed position during long term storage. Any packaging removed for inspection of the valves should be replaced prior to placing the valves into long term storage.

# INSTALLATION

**WARNING:** *Installation of valves should be performed by experienced installers. Valves should never be used as structural supports and must be appropriately rigged for lifting and movement into place. Valves are heavy and may include accessories or bolt on pieces which should be handled with caution.*

**NOTE:** *It is recommended that valves be installed into piping system in accordance with AWWA M-11 to prevent any undue piping stress, deflection or bending that may affect the performance of the valve.*

All supplied AWWA swing check valves bolt between ASME/ANSI B16.1, Class 125 flanges.

1. Swing check valves are always installed with the hinge pin parallel to the plane of the horizon and above the pipe centerline. Incorrect installation may result in binding, high head loss and/or hanging open.
2. Valves must be installed with the flow horizontal or the flow up if installed vertically.
3. Outside lever swing check valves must be installed with the end of the lever that is fixed to the hinge pin higher than the opposite end. Failure to do this will certainly void the function of the check valve and may result in backflow.
4. Lift swing check valves with a sling around the body. Never lift valves by placing a bar or fork through the valve.
5. Allow two pipe diameters clearance minimum from the top of the cover for removal of the disc without removing the valve from the line.

# MAINTENANCE

Excepting misuse and sever service, maintenance should be limited to the following:

1. Sealing surfaces.
2. Bearing surfaces (hinge pins, hinges, and side plugs).
3. Replacement of parts subject to corrosion.
4. Lubrication and repacking of hinge pin stuffing boxes and O-ring stuffing boxes for outside lever valves.

Replacement of resilient disc rings and lubrication and repacking of stuffing boxes for outside lever valves are the only items subject to regular replacement maintenance or repair.

Replacement of parts subject to corrosion is unpredictable, as corrosion conditions are unknown and subject to many variables. Only the field service representative is qualified to judge when a part is corroded beyond use or safe limits and should be replaced.

## RESILIENT DISCS:

Resilient disc rings should be replaced whenever leakage is judged to be excessive, or at scheduled intervals. No special tools are needed for replacement. Replacement parts should be ordered from the factory to ensure correct sizing.

## GRAVITY CHECK VALVE RESILIENT DISC REPLACEMENT:

1. Remove the valve cover.
2. Remove side plugs. Use an appropriate size socket or box wrench, not an adjustable or pipe wrench.
3. Drive hinge pin out with wooden dowel.
4. Lift hinge/disc assembly from valve. "V" notches inside of valve provide clearance for disc assembly.
5. Remove nut retaining disc plate. At this time, it might be advisable to remove the disc bolt and replace the O-ring(s) or gasket on the disc bolt. [CONT'D]

6. Allow a minimum of one pipe diameter on one side of the valve and 2 ½ pipe diameters on the opposite side for removal of the hinge pin.
7. If space is limited, consult the factory for space limitations with outside lever valves. **WARNING:** The levers may be a safety hazard for personnel and lever valves should be installed where personnel will not normally be in the area or guards should be installed.
8. Verify that the valves end flanges conform to the flanges of the connecting pipe and any soiled surfaces are cleaned prior to installation.
9. Remove any materials or shipping items remaining on the valve or restraining the disc or pin during shipment or storage. Attach any outside closing mechanisms manually in the proper position.
10. Lever arms and internal disc should be checked to ensure free travel and motion for proper operation.
11. Ensure the valve is installed in the proper orientation in relation to the flow for correct operation.
12. Standard wrenches or sockets are to be used to tighten all nuts and bolts during installation. Tighten fasteners in a star pattern to ensure load balance of the bolts.

# OPERATION

Once installed in the pipeline swing check valves operate as flow conditions dictate. The valve disc will move to the open position as pressure on the upstream side of the valve is greater than pressure on the downstream side. The valve disc will move to the closed position as flow pressure reduces or reverses and pressure equalizes.

Swing check valves are self-contained units and outside levers, weights and springs should never be used to manually operate the valve or restrict operation of the valve. Any installed shields and surrounding equipment should not interfere with the operation of the valve or external accessories.

Valves provided with air or oil cushioning devices are set at the midpoint mark at the factory. Adjustment may be required after installation dependent on the pressure of flow through the valve.

6. Lift the disc plate off. If the disc plate sticks tap the back of the disc assembly with a soft faced mallet.
7. Remove the resilient disc ring and clean the pocket where the disc ring seats in the disc holder.
8. Replace the resilient disc ring with a new one, seating it flat and centered in the pocket in the disc holder. Do not use gasket sealant.
9. Clean the back of the disc plate.
10. Polish the seat ring in the valve body with crocus cloth or 60 grit wet/dry sandpaper.
11. If the disc bolt has been removed, lubricate the hole in the disc holder and the disc bolt with clean grease carefully inserting the disc bolt through the hinge and disc holder taking care not to twist or cut the O-ring(s).
12. Replace the disc holder by positioning it over the threaded portion of the disc bolt.
13. Replace the disc bolt nut and use a low strength anaerobic sealant. Tighten the nut only to the point that the disc plate makes a very slight impression into the resilient disc ring. Do not over tighten the disc bolt nut.
14. Carefully position the disc/hinge assembly through the cover flange and align with side plug holes and insert the hinge pin.
15. Replace the side plugs by hand, then tighten with 300 in-lb. torque.
16. Inspect the cover sealing surfaces and clean if needed. Inspect the cover gasket or O-ring and replace if needed.
17. Tighten the cover bolts in an alternating pattern, tightening two bolts at 180° snug, then tighten two bolts 90° to the first two and 180° to each other. Finally, tighten all bolts tight.
18. Pressurize and bleed the valve checking for any leaks and tighten joints, as necessary.

## **OUTSIDE LEVER VALVES RESILIENT DISC REPLACEMENT:**

1. Remove spring or weight before removing cover.
2. Loosen setscrew on lever and remove lever and key.
3. Remove side plug packing gland.
4. Remove side plug opposite hinge pin.
5. If setscrews are used on hinge, remove them.
6. Lubricate extended hinge pin.
7. Remove side plug stuffing box from valve.
8. Drive the hinge pin out with a hardwood dowel.
9. Lift hinge/disc assembly from valve. "V" notches inside of valve provide clearance for disc assembly.
10. Remove nut retaining disc plate. At this time, it might be advisable to remove the disc bolt and replace the O-ring(s) or gasket on the disc bolt.
11. Lift the disc plate off. If the disc plate sticks tap the back of the disc assembly with a soft faced mallet.
12. Remove the resilient disc ring and clean the pocket where the disc ring seats in the disc holder.
13. Replace the resilient disc ring with a new one, seating it flat and centered in the pocket in the disc holder. Do not use gasket sealant.
14. Clean the back of the disc plate.
15. Polish the seat ring in the valve body with crocus cloth or 60 grit wet/dry sandpaper.
16. If the disc bolt has been removed, lubricate the hole in the disc holder and the disc bolt with clean grease carefully inserting the disc bolt through the hinge and disc holder taking care not to twist or cut the O-ring(s).
17. Replace the disc holder by positioning it over the threaded portion of the disc bolt.

18. Replace the disc bolt nut and use a low strength anaerobic sealant. Tighten the nut only to the point that the disc plate makes a very slight impression into the resilient disc ring. Do not over tighten the disc bolt nut.
19. Carefully position the disc/hinge assembly through the cover flange and align with side plug holes and insert the hinge pin.
20. Lubricate hinge pin and start hinge pin and key into the hinge.
21. Replace the side plug.
22. Drive hinge pin with a soft tool ensuring that the key and key seats remain lined up.
23. Replace set screws in hinge if required.
24. Repack or replace rings in the side plug stuffing box.
25. Start packing gland into side plug stuffing box.
26. Replace lever, lever key, and setscrew on extended hinge pin.
27. Tighten side plug stuffing box tightening slowly and move lever frequently so as not to over tighten and cause valve to hand open.
28. Replace the cover, spring, or weight.
29. Pressurize and bleed the valve checking for any leaks and tighten joints, as necessary.

### **SEAT RINGS/DISC RINGS:**

Seat rings and/or disc rings should be polished when leakage is considered excessive. No special parts or tools are required.

1. Remove the valve cover.
2. Remove side plugs. Use an appropriate size socket or box wrench, not an adjustable or pipe wrench.
3. Drive hinge pin out with wooden dowel.

4. Lift hinge/disc assembly from valve. "V" notches inside of valve provide clearance for disc assembly.
5. Remove nut retaining disc plate. At this time, it might be advisable to remove the disc bolt and replace the O-ring(s) or gasket on the disc bolt.
6. Lift the disc plate off. If the disc plate sticks tap the back of the disc assembly with a soft faced mallet.
7. Inspect seat ring and disc ring. Polish away any scale and check for nicks and scratches.
8. For metal to metal valves lay a piece of wet/dry paper on a very flat surface and polish the disc ring with a wiping and rotating motion until the entire brass disc ring is smooth, flat, and free of scratches.
9. Wipe the entire surface of the seat ring. It must be smooth, flat, and free from radial scratches.
10. Replace the disc holder by positioning it over the threaded portion of the disc bolt.
11. Replace the disc bolt nut and use a low strength anaerobic sealant. Tighten the nut only to the point that the disc plate makes a very slight impression into the resilient disc ring. Do not over tighten the disc bolt nut.
12. Carefully position the disc/hinge assembly through the cover flange and align with side plug holes and insert the hinge pin.
13. Replace the side plugs by hand, then tighten with 300 in-lb. torque.
14. Inspect the cover sealing surfaces and clean if needed. Inspect the cover gasket or O-ring and replace if needed.
15. Tighten the cover bolts in an alternating pattern, tightening two bolts at 180° snug, then tighten two bolts 90° to the first two and 180° to each other. Finally tighten all bolts tight.
16. Pressurize and bleed the valve checking for any leaks and tighten joints, as necessary.

## REPLACING OIL CUSHION ASSEMBLY (2"-12"):

**CAUTION:** System must be shut down to ensure no unexpected movement arms and cylinders.

1. Remove clevis pin.
2. Remove cap screws for outer cylinder bracket.
3. Remove outer cylinder bracket and bushing.
4. Remove oil cushion assembly.
5. Using replacement oil cushion assembly, re-assemble by following above steps in reverse order.

6. For needle valve adjustment, initially set the needle valve adjustment wide open (fully counter-clockwise) at the time of start-up. From there the customer can close the needle valve (turn adjustment clockwise) in increments of 1/4 or 1/2 turn for each test cycle until they get the desired affect of Check Valve operation.
7. Valve opening from flow can be sudden. Install guarding or ensure persons are well clear from valve after adjustment.

**NOTE:** Can not add an Oil Cushion to a standard valve.

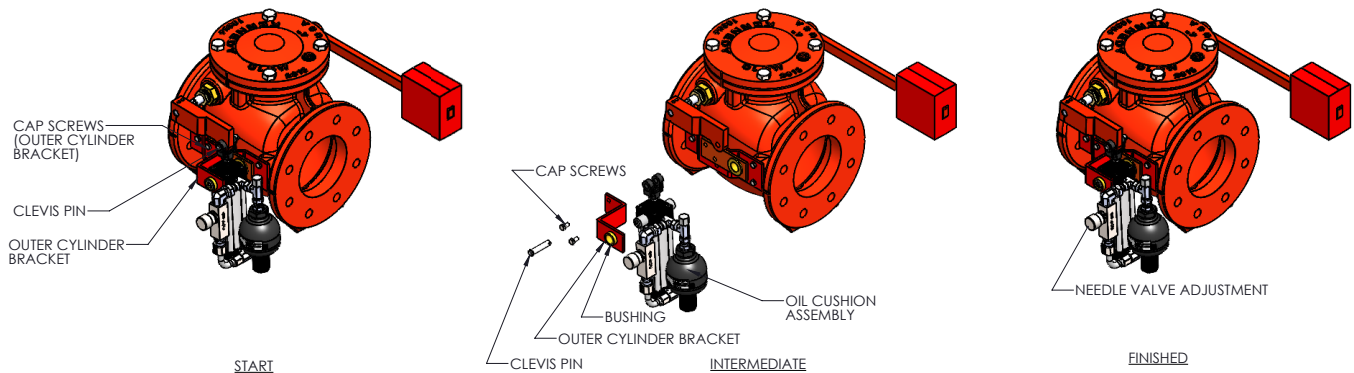

## AIR CUSHION CHECK VALVE GUIDELINES

1. Air cushioned check valves can only be installed in a horizontal application.
2. The flow control valve will have to be more closed for a slower clapper descent; it will have to be more open for a quicker clapper descent. The desired clapper closing speed is to be determined by the end user.
3. Cycle the check valve several times to ensure the flow control valve is at the desired flow rate.
4. See chart below for maximum recommended back pressures. Back pressures exceeding these limits may damage the air cylinders.

CV SIZE	BACK PRESSURE	CYLINDER QTY
14"	9 PSI	1
16"	6 PSI	1
18"	4 PSI	1
20"	5 PSI	1
24"	2 PSI	1
30"	Consult Factory	Consult Factory
36"	Consult Factory	Consult Factory

# OIL CUSHION CHECK VALVE GUIDELINES

1. Oil cushioned check valves can only be installed in a horizontal application.
2. ISO AW 32, 46 or 68 hydraulic oils are recommended for use in the oil cushion cylinder.
3. Flow control valve setting will vary depending in hydraulic oil viscosity (weight). Lighter weights will require the flow control valve to be more closed, heavier weights will require the valve to be more open. The desired closing speed id to be determined by the end user.
4. For check valves utilizing one cylinder cushion, fill the hydraulic oil reserve to the halfway mark, per the fill gauge on the side (approximately 1.5 gallons); for check valves utilizing two cylinder cushions, fill the hydraulic oil reserve to the full mark, per the fill gauge on the side (approximately 3.0 gallons).
5. After filling the hydraulic oil reserve to the appropriate level, cycle the check valve several times to purge air from the hydraulic system. Recheck oil level and add additional, if needed.
6. See chart below for maximum recommended back pressures. Back pressures exceeding these limits may damage the oil cylinders.

CV SIZE	BACK PRESSURE	CYLINDER QTY
14"	55 PSI	1
16"	35 PSI	1
18"	28 PSI	1
20"	22 PSI	1
24"	12 PSI	1
30"	14 PSI	2
36"	Consult Factory	Consult Factory



# TROUBLESHOOTING

<b>PROBLEM</b>	<b>CAUSE</b>	<b>SOLUTION</b>
<b>End joint leakage</b>	Loose bolts	Tighten bolts in a star pattern
<b>Leakage from valve cover</b>	Loose cover bolts	Tighten bolts in a star pattern. Replace cover gasket if leakage continues.
<b>Valve slams when closing</b> (Spring)	Spring tension	Tighten spring adjustment
<b>Valve slams when closing</b> (Weight)	Incorrect weight position on lever	Reposition the weight as needed
<b>Seat leakage</b>	Dirty or damaged seat	Remove cover and flush valve
<b>Leakage by hinge</b>	Torn or damaged O-rings	Replace O-rings.

## PARTS & SERVICE

Parts and service are available from your local representative or the factory. For availability and pricing of spare parts please contact the MPI sales team:

### **McWane Plant & Industrial**

[www.mcwanepi.com](http://www.mcwanepi.com)

Phone: 866-924-8674

Email: [sales@mcwanepi.com](mailto:sales@mcwanepi.com)

# SWING CHECK VALVE

## GRAVITY/PLAIN Fig. 1106 Sizes 2" -12"

PARTS LIST		
PART No.	PART	MATERIAL & ASTM DESIGNATION
1A	Side Plug	Bronze B371 C69300
2A	Hex Bolt	SS18-8
3A	O-ring Seal Cover to Body	Buna-N
4A	Check Valve Cap	Gray, Cast Iron ASTM A 126B
5A	Body	Gray, Cast Iron
7A	Hinge	Bronze (2"-3") / D.I. (4"-12")
8AA	Disc Bolt - Fig. 1106 (Metal to Metal)	Steel (4"-8") / Bronze (10" & 12")
8AB	Disc Bolt - Fig. 1106A (Resilient)	Bronze (4"-12")
9AA	Disc Bolt O-ring	Buna-N (10" & 12")
9AB	Disc Bolt Gasket	Fibre (4"-8")
10A	Disc Holder - Fig. 1106A	Gray, Cast Iron (4"-12", exc. 8")
10A	Disc Holder with Integral Bolt	Bronze (2"-3")
11A	Disc Plate - Fig. 1106A	Bronze
12AA	Replacable Rubber Disc - Fig. 1106A	Rubber
12AB	Disc with Integral Bronze Ring - Fig. 1106	Gray, Cast Iron (4"-12")
12AB	Disc with Integral Bolt and Ring - Fig. 1106	Bronze (2"-3")
13A1	Hex Nut-Disc - Fig. 1106	SS18-8 (2"-12")
13A2	Hex Nut-Disc Holder - Fig. 1106A	SS18-8 (2"-3")
14AA	Disc Ring Integral with Disc - Fig. 1106	Bronze (4"-12")
15A	Seat Ring	Bronze B584 C89833 / C87850
17	Hinge Pin	Stainless Steel SS A-276 (304)

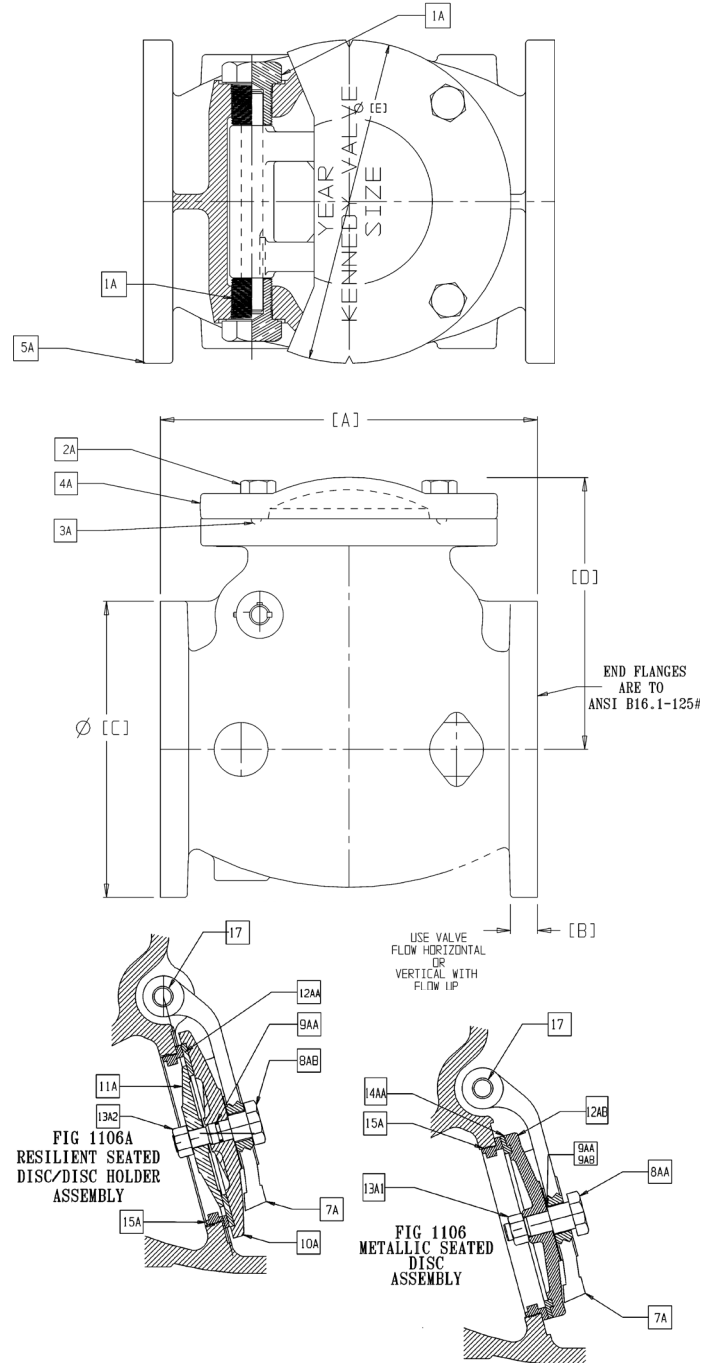

SIZE	DIMENSIONS						WEIGHTS
	DA LG	FLG THK	FLG DD	DA HT	COVER DD	WALL THK	PLAIN
2	8	0.66	6	6	6	0.34	35
2 ½	8.5	0.72	7	6.44	7	0.41	50
3	9.5	0.78	7.5	6.85	7.5	0.44	61
4	11.5	1.00	9	8.69	9	0.50	119
6	14	1.06	11	10.51	11	0.62	190
8	19.5	1.25	13.5	12.56	13.5	0.75	347
10	24.5	1.31	16	14.07	16.75	0.81	566
12	27.5	1.38	19	16.13	19	0.88	774

### NOTES:

- Standard syntax for a standard check valve is:  
161XXXX1106 (brass to brass) or  
161XXXX1106A (resilient to brass), where XXXX signifies the size.
- A special "Buy America" valve can be obtained by specifying "DOM" after the standard number.

# SWING CHECK VALVE WITH LEVER AND WEIGHT Fig. 1106 LW Sizes 2"-12"

PARTS LIST		
PART No.	PART	MATERIAL & ASTM DESIGNATION
1A	Side Plug	Bronze B371 C69300
2A	Hex Bolt	SS18-8
3A	O-ring Seal Cover to Body	Buna-N
4A	Check Valve Cap	Gray, Cast Iron ASTM A 126B
5A	Body	Gray, Cast Iron ASTM A 126B
7AB	Keyed Hinge with Lever(s)	Bronze (2"-3") / D.I. (4"-12")
8AA	Disc Bolt - Fig. 1106 (Metal to Metal)	Steel (4"-8") / Bronze (10" & 12")
8AB	Disc Bolt - Fig. 1106A (Resilient)	Bronze (4"-12")
9AA	Disc Bolt O-ring	Buna-N (10" & 12")
9AB	Disc Bolt Gasket	Fibre (4"-8")
10A	Disc Holder - Fig. 1106A	Gray, Cast Iron (4"-12", exc. 8")
10A	Disc Holder with Integral Bolt	Bronze (2"-3")
11A	Disc Plate - Fig. 1106A	Bronze
12AA	Replacable Rubber Disc - Fig. 1106A	Rubber
12AB	Disc with Integral Bronze Ring - Fig. 1106	Gray, Cast Iron (4"-12")
12AB	Disc with Integral Bolt and Ring - Fig. 1106	Bronze (2"-3")
13A1	Hex Nut-Disc - Fig. 1106	SS18-8 (2"-12")
13A2	Hex Nut-Disc Holder - Fig. 1106A	SS18-8 (2"-3")
14AA	Disc Ring Integral with Disc - Fig. 1106	Bronze (4"-12")
15A	Seat Ring	Bronze B584 C89833 / C87850
17A	Hinge Pin	Stainless Steel SS A-276 (304)
18A	Key	
22A	Set Screw for Weight	Steel, Plated A307
23A	Weight	Gray Iron A1258
24A	Side Plug Stuffing Box	Bronze B371 C69300
25A	Packing	Non-Asbestos
26A	Gland	Stainless Steel B371 C69300
28A	Lever Set Screw	Steel
29A	Washers	Stainless Steel

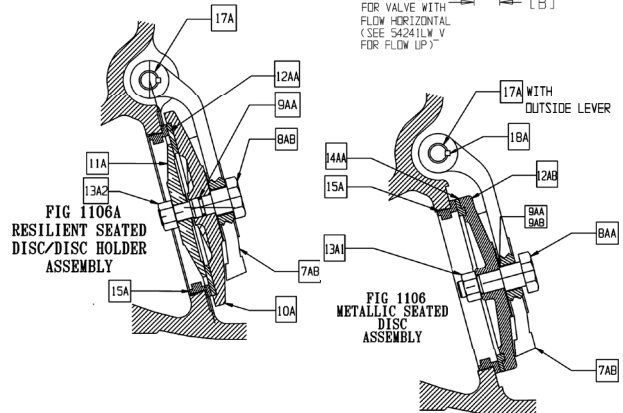
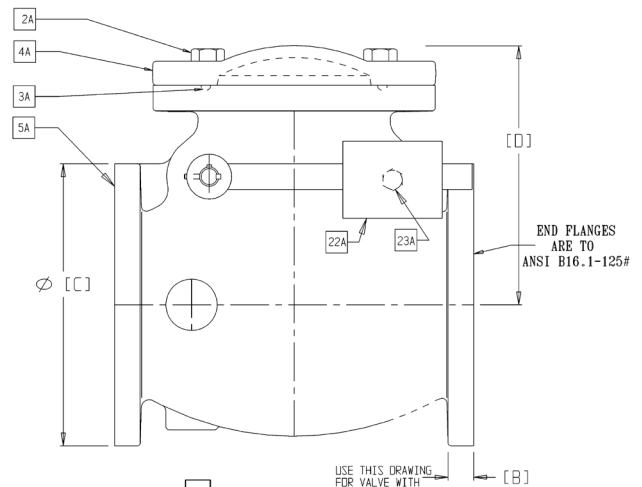
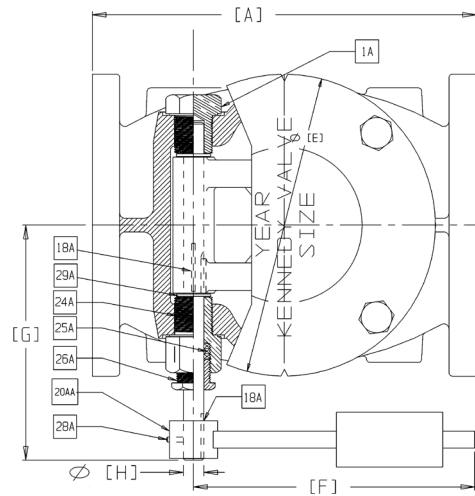

DIMENSIONS							
	DA LG	FLG THK	FLG DD	DA HT	COVER DD	WALL THK	WEIGHTS
Size	AB		CD		EJ		
2"	8"	0.66"	6"	6"	0"	.34"	39
2.5"	8.5"	0.72"	7"	.44"	7"	0.41"	54
3"	9.5"	0.78"	7"	.5"	7.5"	0.44"	65
4"	11.5"	1.00"	9"	8.69"	9"	.50"	128
6"	14"	1.06"	11"	11"	1"	.62"	201
8"	19.5"	1.25"	13.5"	12.56"	11"	0.75"	370
10"	24.5"	1.31"	16"	14.07"	12"	.81"	600
12"	27.5"	1.38"	19"	16.13"	14"	0.88"	812

# SWING CHECK VALVE WITH LEVER AND SPRING Fig. 1106 LS Sizes 2"-12"

PARTS LIST		
PART No.	PART	MATERIAL & ASTM DESIG.
1A	Side Plug	Bronze B371 C69300
2A	Hex Bolt	SS18-8
3A	O-ring Seal Cover to Body	Buna-N
4A	Check Valve Cap	Gray, Cast Iron ASTM A 126B
5A	Body	Gray, Cast Iron ASTM A 126B
7AB	Keyed Hinge with Lever	Bronze (2"-3") / D.I. (4"-12")
8AA	Disc Bolt - Fig. 1106 (Metal to Metal)	Steel (4"-8")
8AA	Disc Bolt - Fig. 1106 (Metal to Metal)	Bronze (10" & 12")
8AB	Disc Bolt - Fig. 1106A (Resilient)	Bronze (4"-12")
9AA	Disc Bolt O-ring	Buna-N (10" & 12")
9AB	Disc Bolt Gasket	Fibre (4"-8")
10A	Disc Holder - Fig. 1106A	Gray, Cast Iron (4"-12", exc. 8")
10A	Disc Holder with Integral Bolt	Bronze (2"-3")
11A	Disc Plate - Fig. 1106A	Bronze
12AA	Replacable Rubber Disc - Fig. 1106A	Rubber
12AB	Disc with Integral Bronze Ring - Fig. 1106	Gray, Cast Iron (4"-12")
12AB	Disc with Integral Bolt and Ring - Fig. 1106	Bronze (2"-3")
13A1	Hex Nut-Disc - Fig. 1106	SS18-8 (2"-12")
13A2	Hex Nut-Disc Holder - Fig. 1106A	SS18-8 (2"-3")
14AA	Disc Ring Integral with Disc - Fig. 1106	Bronze (4"-12")
15A	Seat Ring	Bronze B584 C89833 /C87850
16A	Spring	Steel
17A	Hinge Pin	Stainless Steel SS A-276 (304)
18A	Key	- - -
20AA	Lever Arm (for L/S)	Steel
21A	Bracket (for D/S)	Steel
22A	Hex Head Bolt (L/S Bracket)	Steel A307
23A	Eye Bolt w/ 2 Hex Nuts	Steel A1258
24A	Side Plug Stuffing Box	Bronze B371 C69300
25A	Packing	Non-Asbestos
26A	Gland	Stainless Steel B371 C69300
28A	Lever Set Screw	Steel
29A	Washers	Stainless Steel

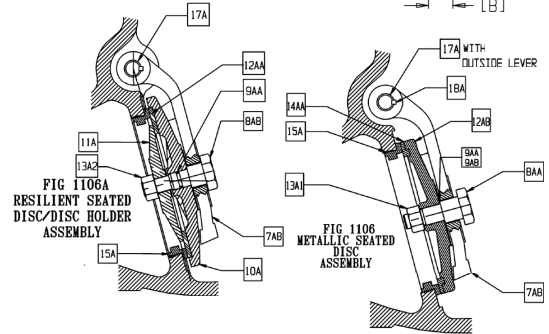
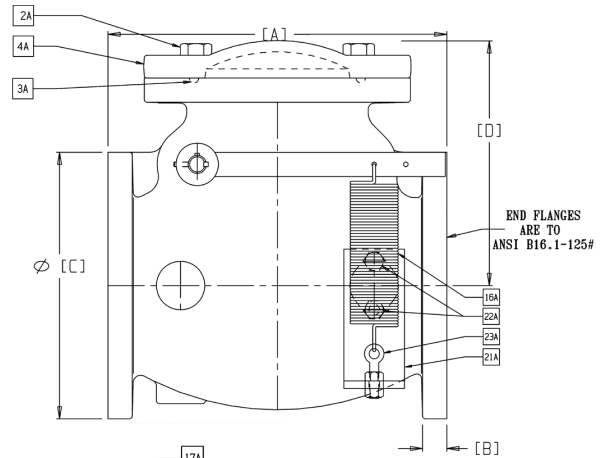
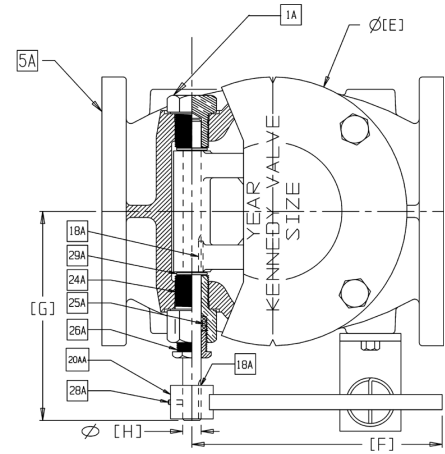

SIZE	DIMENSIONS									L & S WEIGHTS
	DA LG	FLG THK	FLG DD	DA HT	COVER DD	LEVER LG	CL to PIN END	PIN DIA	WALL THK	
	A	B	C	D	E	F	G	H	J	
2	8	0.66	6	6	6	6	4.72	0.50	0.34	39
2 ½	8.5	0.72	7	6.44	7	6	4.94	0.50	0.41	54
3	9.5	0.78	7.5	6.85	7.5	6	5.35	0.50	0.44	65
4	11.5	1.00	9	8.69	9	7.75	8.19	0.63	0.50	128
6	14	1.06	11	10.51	11	9.75	9	0.75	0.62	201
8	19.5	1.25	13.5	12.56	13.5	14.13	10.19	0.88	0.75	370
10	24.5	1.31	16	14.07	16.75	18	11.63	1.00	0.81	600
12	27.5	1.38	19	16.13	19	18	13.75	1.00	0.88	812

# SWING CHECK VALVE WITH LEVER AND WEIGHT WITH AIR CUSHION

## Sizes 2" - 12"

PARTS LIST		
PART No.	PART	MATERIAL & ASTM DESIGNATION
1	Body	Gray Iron A126 B
2	Cover	Gray Iron A126 B
3	Cover / Body O-ring	Buna-N
4	Cover Bolts	18-8 Stainless F593, F594
5	Seat Ring	Bronze C89833 or C87850
6	Side Plug	Bronze C69300
7	Stuffing Box	Bronze C69300
8	Packing (not shown)	Non-Asbestos by GARLOCK
9	Gland Follower	Bronze C69300
10	Hinge (Keyed)	Ductile Iron
11R	Disc Holder	Iron
12R	Disc, Resilient	Rubber, Buna-N
13R	Disc Plate	Bronze C89833 or C87850
14	Disc Bolt	Brass C69300
15	Nut, Disc Bolt	18-8 Stainless
16	O-ring, Disc Bolt	Buna-N
17	Hinge Pin (H.T.)	431 Stainless Steel
18	Lever	Steel
19	Key for Lever	Stainless Steel
20	Set Screw for Lever	Steel, Plated A307
21	Key for Hinge	Stainless Steel
22	Weight	Gray Iron A126 B
23	Set Screw for Weight	Steel, Plated A307
24	Cylinder Arm	Steel
25	Set Screw for Arm	Steel, Plated A307
26	Body Bracket	Steel
27	Outer Cylinder Bracket	Steel
28	Inner Cylinder Bracket	Steel
29	Cylinder	Materials Vary
30	Bushing(s)	Bronze
31	Rod End	Iron / Steel
32	Pin	Steel
33	Cotter Pin	Stainless
34	Control Valve	Materials Vary
35	Nipple	Brass
36	Muffler	Materials Vary
37	Body Bracket Bolts	Steel, Plated Grade 5
38	Cylinder Bracket Bolts	Steel, Plated Grade 5
39	Lock Washer (HiCollar)	Steel, Plated
40	Nuts (Jam)	Steel, Plated
41	Washers	Stainless Steel

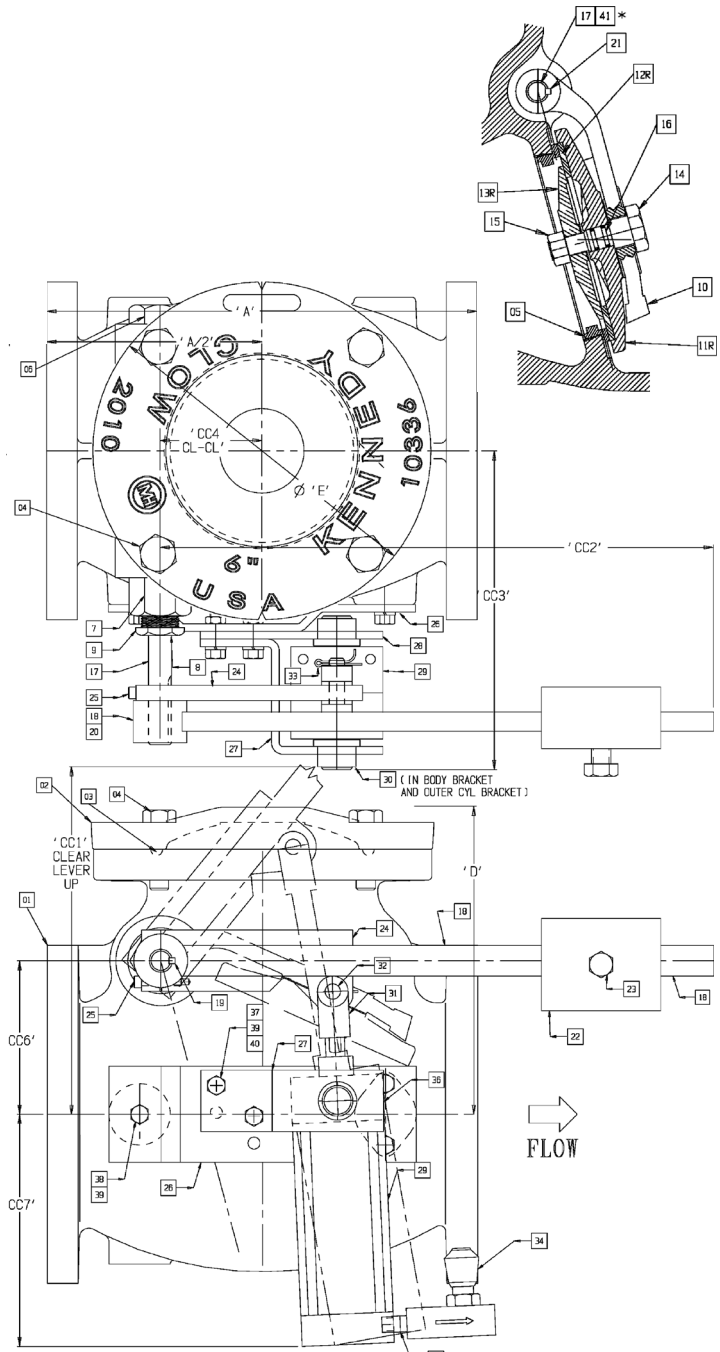

Dimensions are approximate- for Checking Clearances only.  
Allow clearance 2 sides to remove side plug and access hinge pin.

**NOTES:**

- 6" valve shown
- Valve shown with cushion arrangement on right hand size (facing inlet). Left hand version available.
- Valve opening is sudden. Install guards or otherwise assure that persons are well clear.
- Dimensions are approximate and for layout purposes only.
- Configuration for vertical installation different than shown- see specific drawing.
- Standard - Resilient Seated. Special - Metal Seated

**Note:** By their nature, metal seated valves are likely to sound louder than resilient.

SIZE	DIMENSIONS									WEIGHTS
	A	D	E	CC1	CC2	CC3	CC4	CC6	CC7	
4	11.50	8.69	9.00	13.77	12.00	9.56	2.44	3.75	8.89	150
6	14.00	10.51	11.00	19.28	18.00	10.38	3.31	5.00	7.52	226
8	19.50	12.56	13.50	22.24	18.00	11.75	4.88	6.25	6.40	402
10	24.50	14.07	16.75	23.62	18.00	13.68	6.19	7.12	11.46	613
12	27.50	16.12	19.00	24.57	18.00	14.94	8.38	8.19	10.40	862

# SWING CHECK VALVE WITH LEVER AND WEIGHT WITH OIL CUSHION Sizes 2" -12"

PARTS LIST		
PART No.	PART	MATERIAL & ASTM DESIGNATION
1	Body	Gray Iron ASTM A126-B
2	Cap	Gray Iron ASTM A126-B
3	O-Ring, Cap Flange	Rubber; Buna-N
4	Bolt; Cap	18-8 Stainless Steel F593, F594
5	Seat Ring	Bronze C89833 or C87850
6	O-Ring; Seat Ring	Rubber; Buna-N
7	Stuffing Box	C69300 Bronze; 12" 304SS
8	Packing	Non-Asbestos
9	Gland Follower	C69300
10	Hinge (Double Key)	Ductile Iron ASTM A536
11R	Disc Holder	3" Bronze; 4"-12" Gray Iron ASTM A126-B
12R	Disc	Rubber; Nitrile
13R	Disc Plate	3" 18-8 Stainless; 4"-12" Bronze C89833 or C87850
14	Disc Bolt	3" Bronze; 4"-12" Gray Iron ASTM A126-B
15	Disc Bolt Nut	18-8 Stainless Steel F593, F594
16	O-Ring; Disc Bolt	Rubber; Buna-N
17	Hinge Pin; Special	ASTM A579 Grade 73; Tin / Electroless Nickel Plated
18	Lever	Steel
19	Key; Lever	Stainless Steel
20	Set Screw; Lever	Steel Plated
21	Key; Hinge	Stainless Steel; 12" Cold Worked
22	Set Screw; Weight	Steel Plated
23	Cylinder Arm	Steel; 12" 1045 Steel
24	Hex Head Cap Screw; Cylinder	Steel
25	Bracket; Body Cylinder	Steel
26	Bracket, Outer	Steel
27	Bracket, Inner	Steel
28	Hydraulic Cylinder Assembly	see drawing 32450
29	Bushing; Bracket	Steel
30	Clevis Rod End	Steel
31	Coupling Pins; Clevis	Pivot Point Pin
32	Set Screw; Cylinder Arm	Steel Plated
33	Lockwasher; Bracket	Steel Plated
34	Screw; Cylinder Bracket	Steel Plated
35	Nut; Cylinder Bracket	Steel Plated
36	Screw	Steel Plated
37	Weight	Cast Iron
38	Special Washers (Not Shown)	Stainless Steel

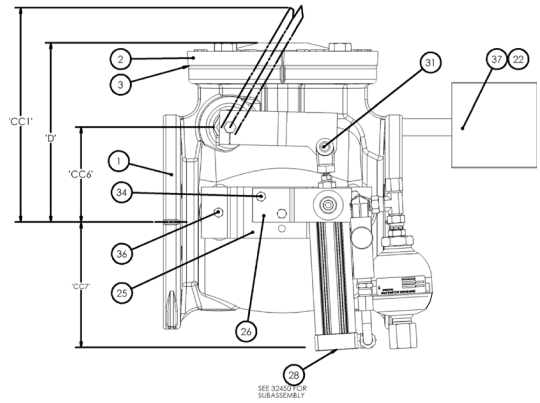
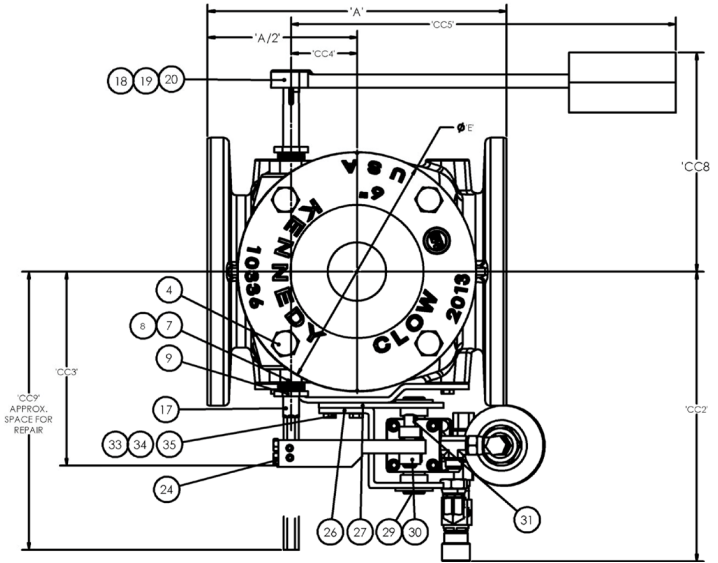

Dimensions are approximate- for Checking Clearances only.  
Allow clearance two sides to remove side plug and access hinge pin.

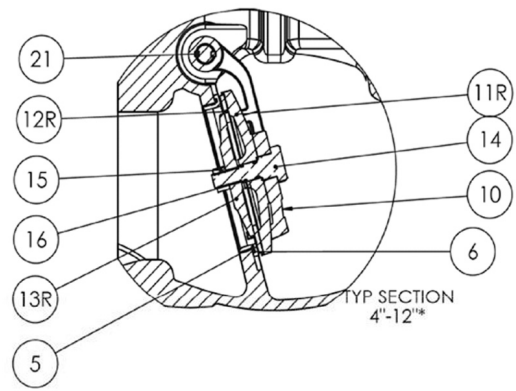

SIZE	DIMENSIONS											WEIGHTS	
	A	D	E	CC1	CC2	CC3	CC4	CC5	CC6	CC7	CC8		CC9
3	9.5	7.5	6.6	14	13	6.3	2.0	11.5	3.32	9	8.0	17.5	92
4	11.5	9	9.1	14	13	8.0	2.4	12	3.75	9	8.5	22	157
6	14.0	10	11.2	20	14	9.6	3.1	18	5	8	9.7	25.5	226
8	19.5	13	13.6	23	15	10.3	4.9	18	6.25	7	11.7	29	412
10	24.5	14	16.8	24	19	12.5	6.2	18	7.12	12	13.3	33	625
12	27.5	16.5	19.1	25	20	13.7	8.4	18	8.19	11	15.5	37	876

# SWING CHECK VALVE

## PARTS LIST Sizes 14" -36"

NOTE: 30" and larger come standard with double lever arms.

PARTS LIST		
PART No.	PART	MATERIAL & ASTM DESIGNATION
1	Body - F.E.	Cast Iron ASTM A126 CL.B
2	Cover Bolts	ASTM A-307 Gr. B or A EZ Plated
3	Cover	Cast Iron ASTM A126 CL.B
4	Cover O-ring	Buna-N Durometer 70 Approved
5	Clapper Arm Key	304 Stainless Steel
6	Set Screw	Alloy Steel (RC 45-63)
7	Hinge Pin	Stainless Steel ASTM A-276 Yupe 303
8	Clapper Arm	Ductile Iron A536 65-45-12 or 70-50-05
9	Clapper Cap Plate	304 Stainless Steel
10	Hex Bolt Cap Plate	18-8 Stainless Steel
11	Clapper Arm Bushing	Brass C26000
12	Clapper	Ductile Iron A536 65-45-12 or 70-50-05
13	Encapsulated Rubber Clamp Ring	Buna-N Durometer 70 Approved
14	Body Ring	Bronze Alloy C89836
15	Washer, Flat	18-8 Stainless Steel
16	Hex Bolt Clamp Ring	18-8 Stainless Steel
17	Stuffing Box Bushing	Bronze Alloy C89850
18	Packing	Multi-Lock Braid Style ML2254 PTFE
19	Stuffing Box Gland	Ductile Iron A536 65-45-12 or 70-50-05
20	Stud	Steel ASTM A307, EZ Plated
21	Hex Nut	18-8 Stainless Steel

### Limit Switch:

22	Tripper Arm	Steel
23	Mounting Bracket	Steel
24	Limit Switch	SD-D-Type-CR53E

### Lever & Weight Check Valve:

25	Weight Lever Arm	Ductile Iron
26	Weight	Fab. Steel
27	Weight Arm Bar	CR Steel C-1018/1020

### Lever & Spring Check Valve:

28	Spring Arm Lever	Ductile Iron
29	Spring Arm Bar	CR Steel C-1018/1020
30	Spring	Steel
31	Spring Bracket Cap Screw	Steel A-307 Grade B
32	Spring Eyebolt	Steel A-307 Grade B
33	Spring Bracket	Steel

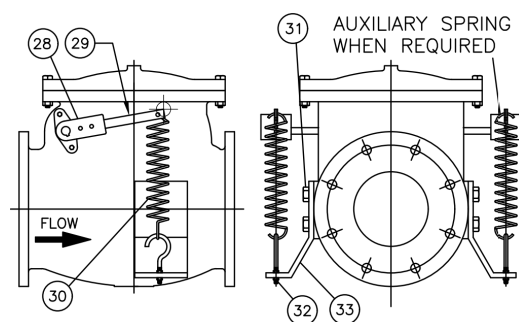
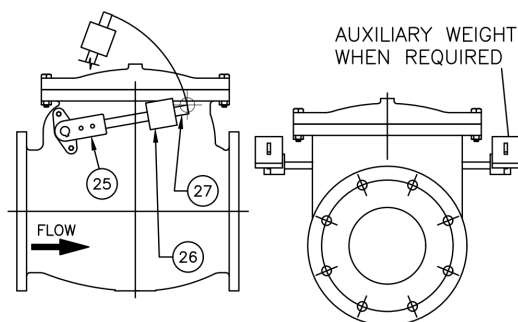
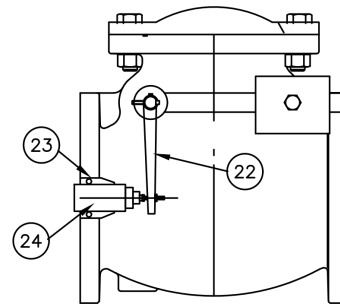
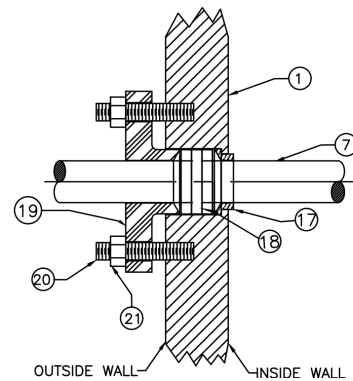
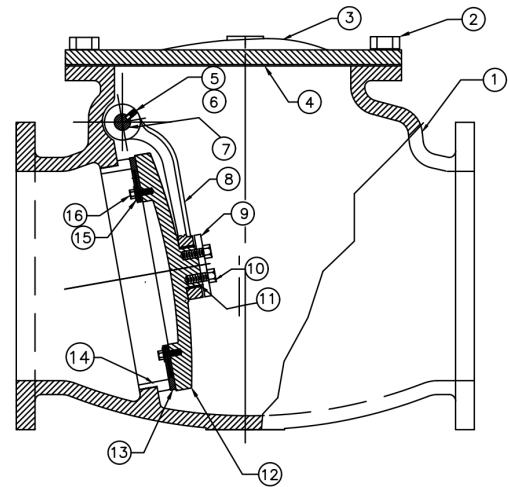

# SWING CHECK VALVE

## DIMENSIONS Sizes 14" -36"

NOTE: 30" and larger come standard with double lever arms.

DIMENSIONS							
SIZE	14	16	18	20	24	30	36
F	31	36	40	40	48	49 1/2	63
G	1 3/8	1 7/16	1 9/16	1 11/16	1 7/8	2 1/8	2 3/8
H	21	23 1/2	25	27 1/2	32	38 3/4	46
J	18 3/4	21 1/4	22 3/4	25	29 1/2	36	42 3/4
K	12-1	16-1	16-1 1/8	20-1 1/8	20-1 1/4	28-1 1/4	32-1 1/2
L	22 3/8	25 3/4	27 1/2	32	34 7/8	41	47
R	18 3/4	19 1/16	25	24 1/2	24 11/16	28	34

### Lever & Spring Check Valves - Style 259-02

T	18 1/2	19	20 3/4	22 1/2	26	28 1/4	35
WEIGHT	1150	1695	1835	2500	3415	4950	

### Lever & Weight Check Valves - Style 159-02

S	19	19 1/2	20 3/4	22 1/2	27 3/8	29 3/8	35
U	32 1/2	34 1/2	40	42	54 1/2	57 1/2	
WEIGHT	1150	1695	1835	2500	3555		

### Plain / Swing Check Valves - 59-02

T	18 1/2	19	20 3/4	22 1/2	26	28 1/4	35
WEIGHT	1060	1460	1775	2400	3450	5200	

#### NOTES:

Check laying lengths when replacing valves that were manufactured prior to 2013.  
Dim "V" consult M&H for max. cut-off of hinge pin to eliminate clearance problems.

